



## Absolute Maximum Ratings

Parameter	Symbol	Value	Unit
Supply voltage	V <sub>CC</sub>	30	V
Output current	I <sub>O</sub>	±1.5	A
Input voltage at overcurrent detection pin	V <sub>IN(IS)</sub>	-0.3 to 4	V
Input voltage at FB pin	V <sub>IN(FB)</sub>	4	V
Input current at CS pin	I <sub>IN(CS)</sub>	2	mA
Total power dissipation (T <sub>a</sub> = 25°C)	P <sub>D</sub>	800	mW
Operating temperature	T <sub>OPR</sub>	-25 to 85	°C
Storage temperature range	T <sub>STG</sub>	-65 to 150	°C
Junction temperature	T <sub>J</sub>	+125	°C

## Electrical Characteristics

(V<sub>CC</sub> = 18V, F<sub>OSC</sub> = 135kHz, T<sub>A</sub> = 25°C, unless otherwise specified)

Parameter	Symbol	Conditions	Min.	Typ.	Max.	Unit
<b>OSCILLATOR SECTION</b>						
Initial accuracy	F <sub>OSC</sub>	C <sub>T</sub> = 360pF, T <sub>J</sub> = 25°C	125	135	145	kHz
Frequency variation 1	ΔF/ΔV	V <sub>CC</sub> = 10V to 30V	-	±1	±3	%
Frequency variation 2 <sup>(Note1)</sup>	ΔF/ΔV	T <sub>A</sub> = 25°C to 85°C	-	±1.5	-	%
Ramp high voltage	V <sub>RH</sub>	C <sub>T</sub> = 360pF, T <sub>J</sub> = 25°C	2.80	3.08	3.30	V
Ramp low voltage	V <sub>RL</sub>	C <sub>T</sub> = 360pF, T <sub>J</sub> = 25°C	0.6	0.9	1.2	V
Amplitude	V <sub>OSC</sub>	V <sub>PIN7</sub> , peak to peak	1.80	2.18	2.50	V
<b>PULSE WIDTH MODULATION SECTION</b>						
Input threshold voltage(pin2)	V <sub>TH(FBD)</sub>	Duty cycle = 0%	0.6	0.75	0.95	V
Input threshold voltage(pin2) <sup>(Note1)</sup>	V <sub>TH(FB1)</sub> (KA7552)	Duty cycle = D <sub>max</sub> 1	2.1	2.3	2.6	V
	V <sub>TH(FB2)</sub> (KA7553)	Duty cycle = D <sub>max</sub> 2	1.6	1.8	2.1	V
Max. duty cycle	D <sub>(Max1)</sub> (KA7552)	-	66	70	74	%
	D <sub>(Max2)</sub> (KA7553)	-	43	46	49	%
Source current(pin2)	I <sub>SOURCE(FB)</sub>	V <sub>PIN2</sub> = 0V	-660	-800	-960	uA
<b>OVERCURRENT LIMIT SECTION</b>						
Input threshold voltage	V <sub>TH(IS)</sub>	-	0.21	0.24	0.27	V
Source current(pin3)	I <sub>SOURCE(IS)</sub>	V <sub>PIN3</sub> = 0V	-300	-200	-100	uA
Deley time <sup>(Note1)</sup>	T <sub>D</sub>	-	-	150	-	ns
<b>SOFT START SECTION</b>						
Charging current	I <sub>CHG</sub>	V <sub>PIN8</sub> = 0V	-15	-10	-5	uA
Input threshold voltage(pin8)	V <sub>TH(CSO)</sub>	-	0.7	0.9	1.1	V
Input threshold voltage(pin8) <sup>(Note1)</sup>	V <sub>TH(CS1)</sub> (KA7552)	Duty cycle = D <sub>max</sub> 1	2.2	2.4	2.6	V
	V <sub>TH(CS2)</sub> (KA7553)	Duty cycle = D <sub>max</sub> 2	1.7	1.9	2.1	V
<b>LATCH MODE SHUTDOWN CIRCUIT SECTION</b>						
Sink current(pin8)	I <sub>SINK(CS)</sub>	V <sub>PIN8</sub> = 6V, V <sub>PIN2</sub> = 1V	25	45	65	uA
Shutdown threshold voltage	V <sub>TH(SD,CS)</sub>	-	6.7	7.2	7.7	V
<b>OVERLOAD SHUTDOWN SECTION</b>						
Shutdown threshold voltage	V <sub>TH(SD,FB)</sub>	-	2.6	2.8	3.1	V

**Electrical Characteristics** (Continued)(V<sub>CC</sub> = 18V, FOSC = 135kHz, T<sub>A</sub> = 25°C, unless otherwise specified)

Parameter	Symbol	Conditions	Min.	Typ.	Max.	Unit
<b>UNDER VOLTAGE LOCKOUT SECTION</b>						
Start-up threshold voltage	V <sub>TH(ST)</sub>	-	15.5	16.0	16.5	V
Minimum operating voltage	V <sub>OPR(Min)</sub>	-	8.20	8.70	9.20	V
Hysteresis	V <sub>HYS</sub>	-	6.40	7.30	8.20	V
<b>ON/OFF CONTROL SECTION</b>						
Source current(pin8)	I <sub>SOURCE(CS)</sub>	V <sub>PIN8</sub> = 0V	-15	-10	-5	uA
On threshold voltage	V <sub>TH(ON)</sub>	V <sub>PIN8</sub> : OFF->ON	0.45	0.56	0.70	V
Off threshold voltage	V <sub>TH(OFF)</sub>	V <sub>PIN8</sub> : ON -> OFF	0.30	0.42	0.55	V
<b>OUTPUT SECTION</b>						
Low output voltage	V <sub>OL</sub>	I <sub>O</sub> = 100mA, V <sub>CC</sub> = 18V	-	1.3	1.8	V
High output voltage	V <sub>OH</sub>	I <sub>O</sub> = -100mA, V <sub>CC</sub> = 18V	16.0	16.5	18.0	V
Rise time <sup>(Note1)</sup>	T <sub>R</sub>	No load	-	50	-	ns
Fall time <sup>(Note1)</sup>	T <sub>F</sub>	No load	-	50	-	ns
<b>OVERALL</b>						
Stand-by current	I <sub>SB</sub>	V <sub>CC</sub> = 14V	-	90	150	uA
Operating current	I <sub>CC(OPR)</sub>	V <sub>PIN2</sub> = 0V	-	9	15	mA
Power supply current off	I <sub>CC(OFF)</sub>	V <sub>PIN8</sub> = 0V	-	1.1	1.8	mA
Power supply current shutdown	I <sub>CC(SD)</sub>	V <sub>PIN8</sub> = 7.6V	-	1.1	1.8	mA

**Note :**

1. These parameters, although guaranteed, are not 100% tested in production.
2. Recommend operating condition :
  - V<sub>CC(min)</sub> = 12V
  - R<sub>T</sub> = 3.3kΩ ~ 10kΩ
  - Oscillation frequency = 5kHz ~ 600kHz
  - Soft start capacitor(C<sub>S</sub>) = 0.1uF ~ 1uF

# Mechanical Dimensions

## Package

Dimensions in millimeters

### 8-DIP

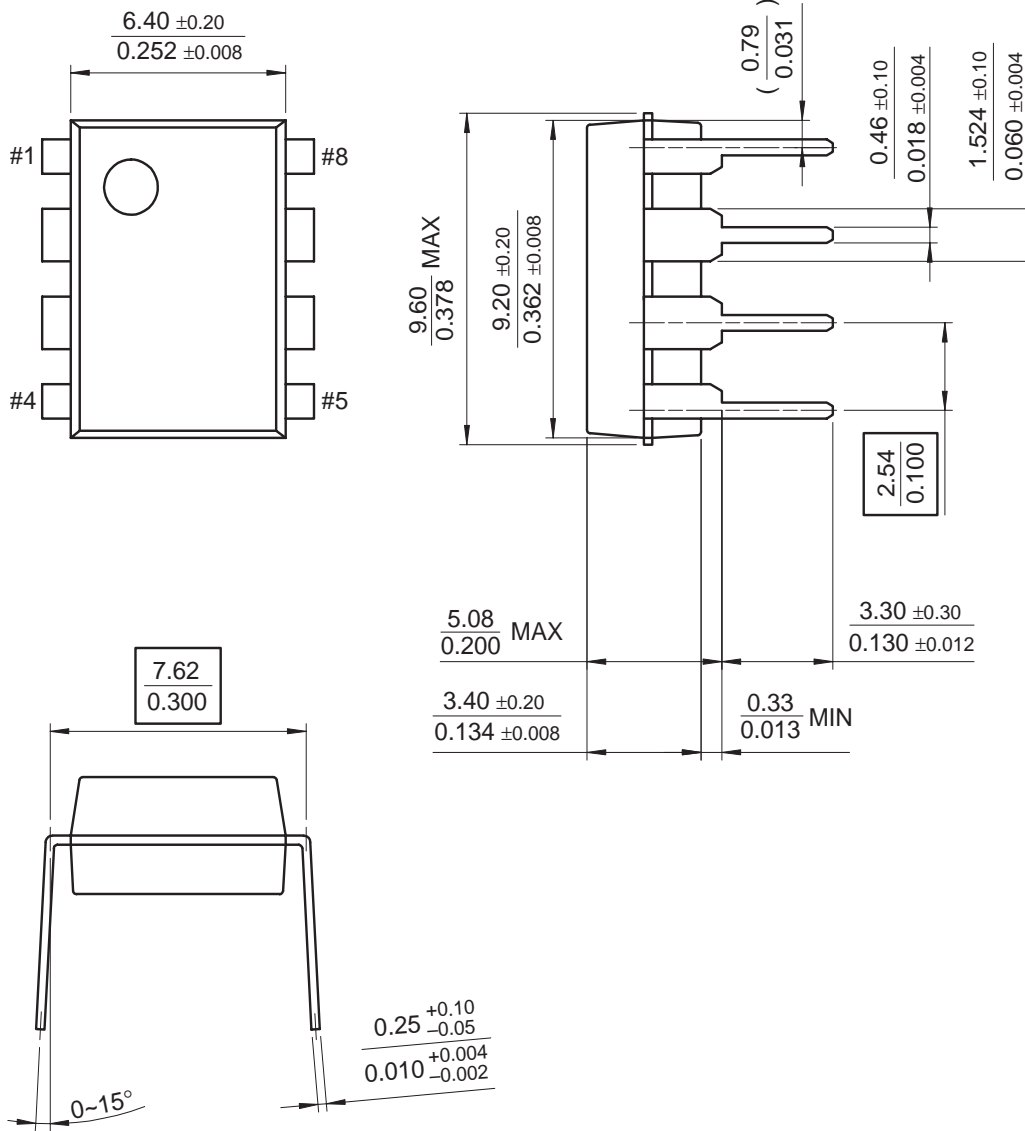

---

## Ordering Information

Product Number	Package	Operating Temperature
KA7552A	8-DIP	-25 ~ +85°C
KA7553A		

**DISCLAIMER**

FAIRCHILD SEMICONDUCTOR RESERVES THE RIGHT TO MAKE CHANGES WITHOUT FURTHER NOTICE TO ANY PRODUCTS HEREIN TO IMPROVE RELIABILITY, FUNCTION OR DESIGN. FAIRCHILD DOES NOT ASSUME ANY LIABILITY ARISING OUT OF THE APPLICATION OR USE OF ANY PRODUCT OR CIRCUIT DESCRIBED HEREIN; NEITHER DOES IT CONVEY ANY LICENSE UNDER ITS PATENT RIGHTS, NOR THE RIGHTS OF OTHERS.

**LIFE SUPPORT POLICY**

FAIRCHILD'S PRODUCTS ARE NOT AUTHORIZED FOR USE AS CRITICAL COMPONENTS IN LIFE SUPPORT DEVICES OR SYSTEMS WITHOUT THE EXPRESS WRITTEN APPROVAL OF THE PRESIDENT OF FAIRCHILD SEMICONDUCTOR CORPORATION. As used herein:

1. Life support devices or systems are devices or systems which, (a) are intended for surgical implant into the body, or (b) support or sustain life, and (c) whose failure to perform when properly used in accordance with instructions for use provided in the labeling, can be reasonably expected to result in a significant injury of the user.
2. A critical component in any component of a life support device or system whose failure to perform can be reasonably expected to cause the failure of the life support device or system, or to affect its safety or effectiveness.